

ANDRITZ centrifugal pump

ACP/ARE series

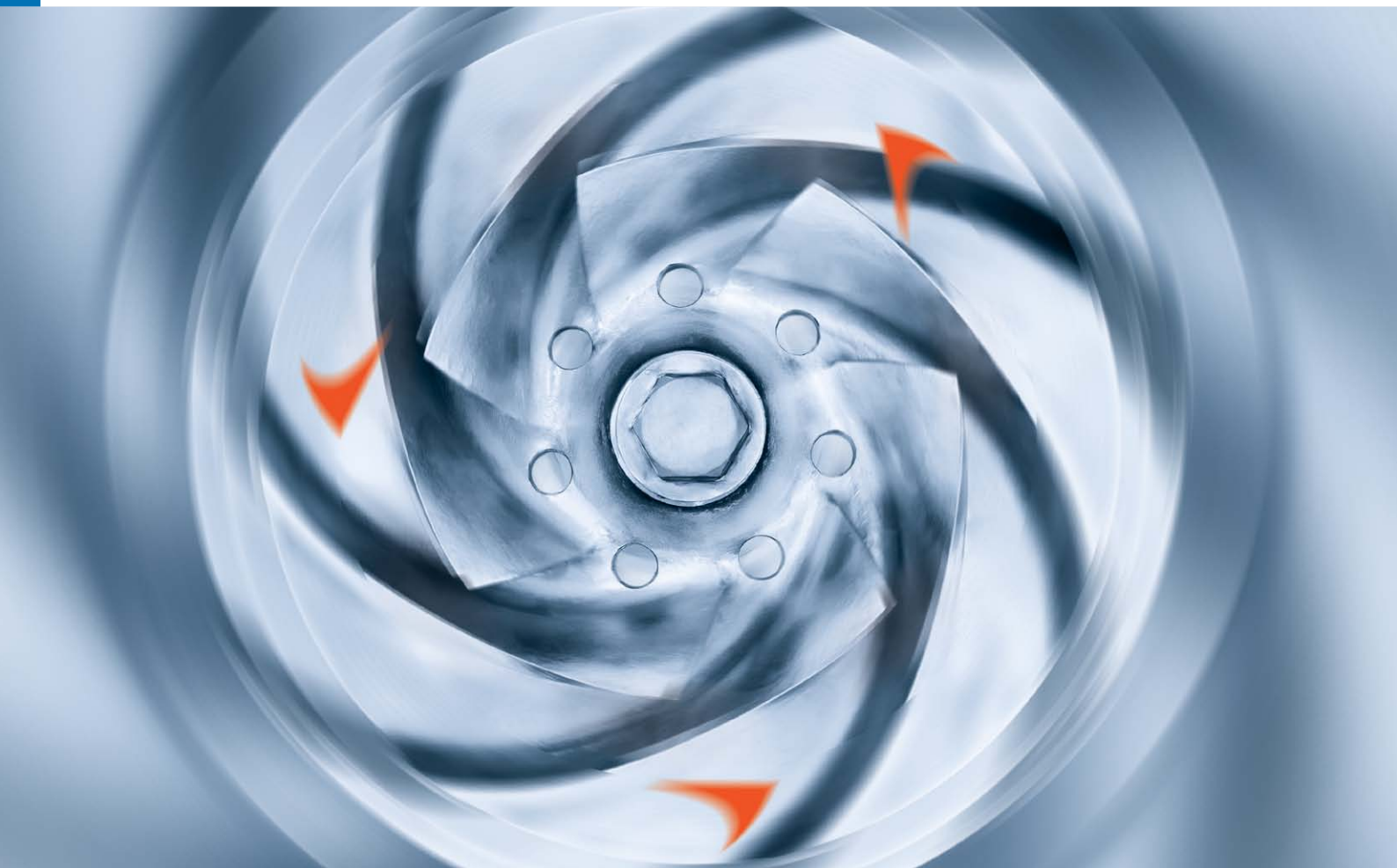

High efficiency and robust design

For over 100 years, ANDRITZ has been a byword for competence and innovation in designing centrifugal pumps.

ANDRITZ horizontal centrifugal pumps are operating successfully all over the world. They offer robustness and wear resistance, and fulfill high customer expectations in terms of efficiency, life cycle, maintenance-friendliness, and economic efficiency.

Modular system

The standard components in ANDRITZ pumps provide high availability and enable the use of proven components.

Fields of application

- Pulp and paper industry
- Water supply and waste water treatment
- Power industry
- Food industry (e.g. sugar)
- Bioethanol
- Chemical industry

Facts

- Flow rates up to 6.000 m³/h
- Heads up to 160 m
- Casing pressure up to 25 bar
- Temperatures up to 200° C
- Consistencies up to 6% atro (ARE-design up to 8% atro)
- Efficiency up to 90%
- Only five bearing support sizes for the entire series!



Technology to convince you

The high standard of ANDRITZ centrifugal pumps, is based on decades of experience in designing hydraulic machines and on extensive process know-how.

SMARTSEP

- Integrated degassing-system for media with high gas content

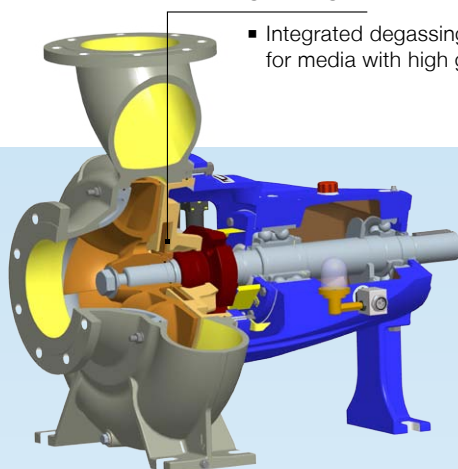

ARE series with SMARTSEP degassing system

ANDRITZ offers the newly developed SMARTSEP-degassing system especially designed for high gas content and stock suspensions of up to 8%. The pump is equipped with an integrated degassing system which removes gas from the media and conveys any fibres back to the pump. Controlling of the degassing valve becomes very easy: pump is running – valve is open, pump is not running – valve is closed.

Proven open-impeller design, series ACP

The open-impeller design of the ANDRITZ centrifugal pumps ACP series is characterized by low axial thrust. With its open channels, it is suitable for conveying many different media.

Shaft sealing

- Single mechanical seal for stock conveyance without sealing and rinsing water
Capital investment and operating cost savings!

Sturdy bearing support

- Single casting with integrated lantern
- Only five bearing support sizes for the entire series

Impeller design

- Open with three blades for a large open cross section
- Semi-open with five to eight blades for high pressures

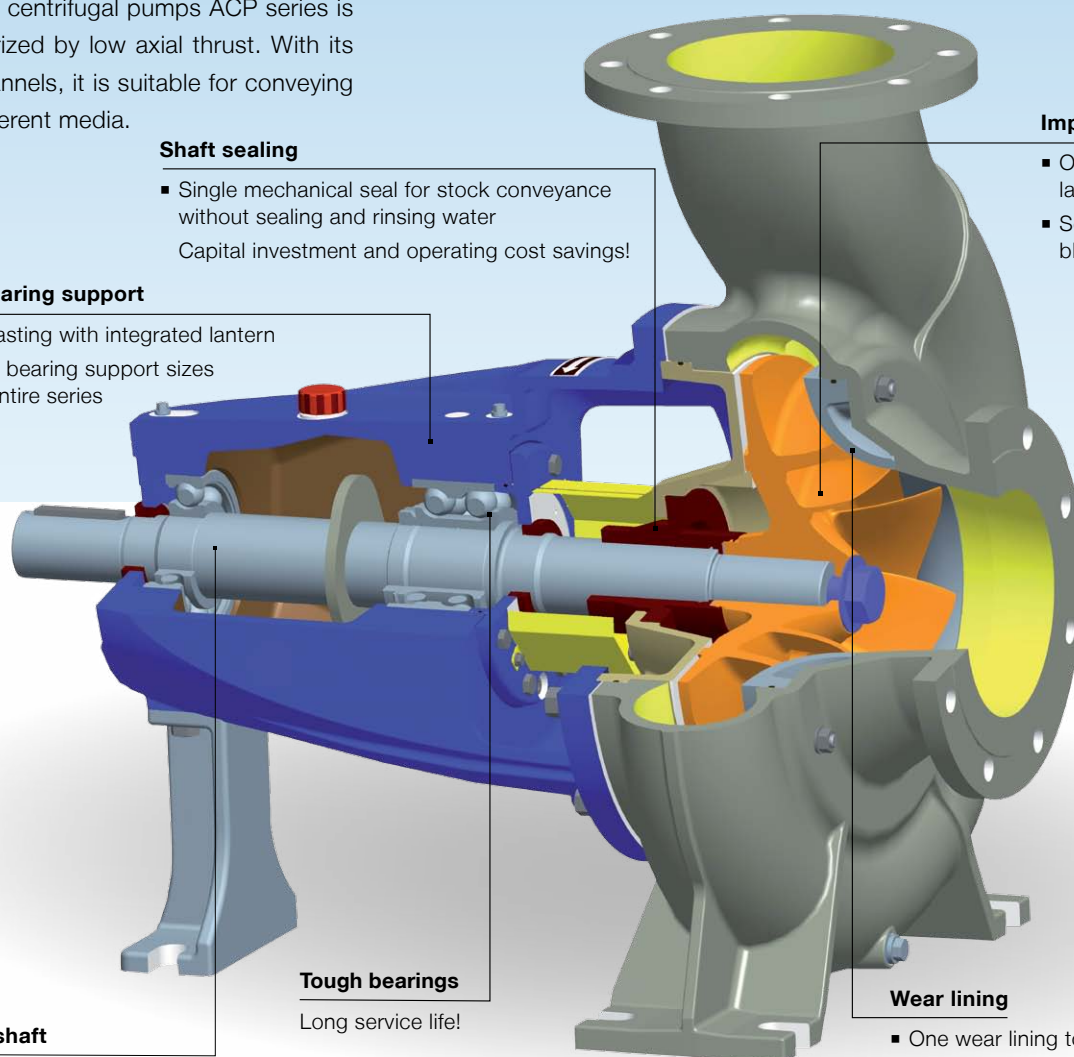

Tough bearings

Long service life!

Wear lining

- One wear lining to protect the pump casing

Sturdy shaft

Ensures minimum shaft deflection and low mechanical vibration!

High research and development capabilities

We run a pilot plant at our affiliate ASTRÖ, which enjoys international renown for its hydraulic developments and investigations. The high quality, safety and reliability of the ACP/ARE series pumps are ensured by extensive model testing.



Various sealing systems

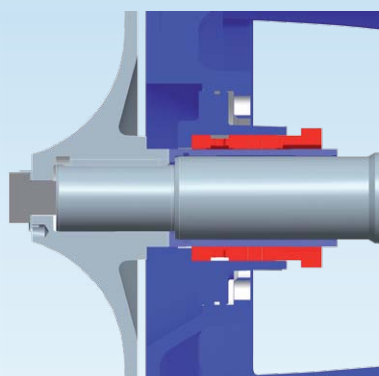

Stuffing box seal

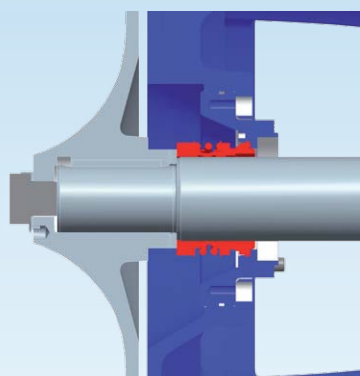

Single mechanical seal

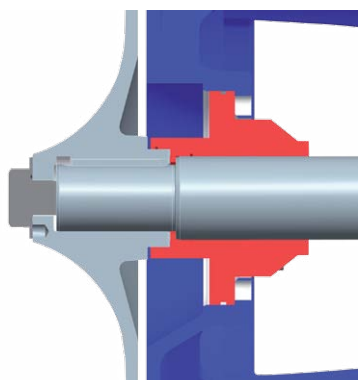

Tandem mechanical seal

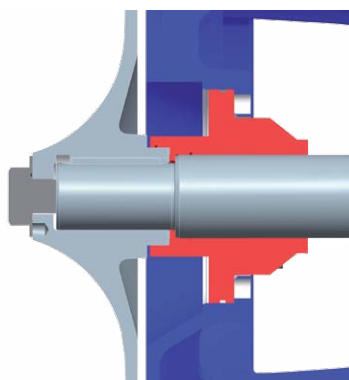

Single or double cartridge seal

Characteristic curves

Centrifugal pumps, ACP/ARE series

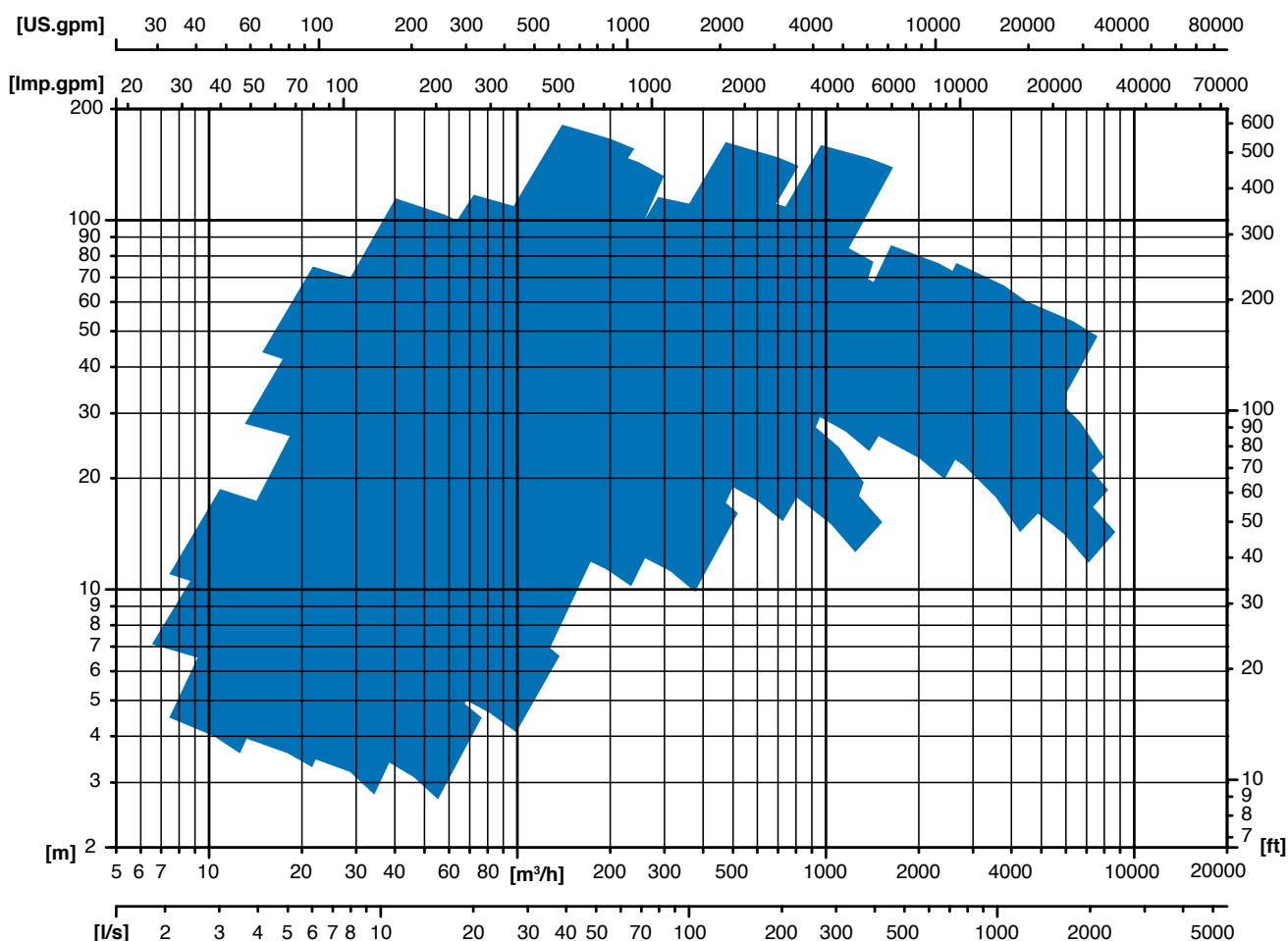

Material combinations

ACP/ARE series	EN-GJL 250	1.4460	1.4021	1.4462	1.4517	1.4517 h	1.4404	1.4439	1.4469
Impeller		■			■	■			■
Casing/casing cover	■	■							■
Bearing housing	■								
Front lining		■			■	■			■
Stuffing box body	■	■							■
Shaft				■					

European standard		US standard	
Number	Name	Grade	UNS
EN-JL1040	EN-GJL 250	Class 40B	/
1.4460	X3CrNiMoN27-5-2	Grade 1A	J93370
1.4462	X2CrNiMoN22-5-3	S32205	S32205
1.4517	GX2CrNiMoCuN25-6-3-3	Grade 1C	J93373
1.4517 h	GX2CrNiMoCuN25-6-3-3	Grade 1C	J93373
1.4469	GX2CrNiMoN26-7-4	Grade 5A	J93404

Close to our customers



ANDRITZ AG

Stattegger Strasse 18
8045 Graz, Austria
Phone: +43 (316) 6902-0
Fax: +43 (316) 6902-413
pumps@andritz.com



www.andritz.com/pumps